

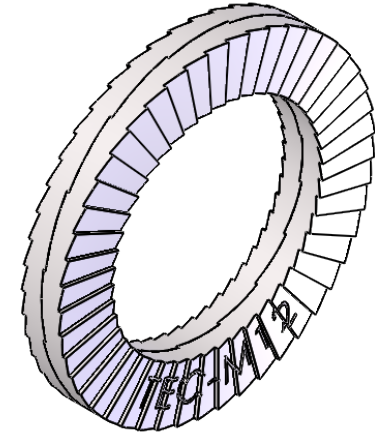

REVISIONS			
REV.	DESCRIPTION	DATE	ECN
A	INITIAL RELEASE	2/27/17	2555
B	HEAT TREAT WAS 480 - 540 HV	3/29/17	2615
C	MATERIAL UPDATE	7/12/2018	3056

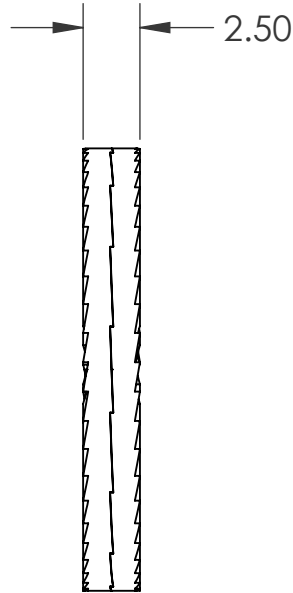
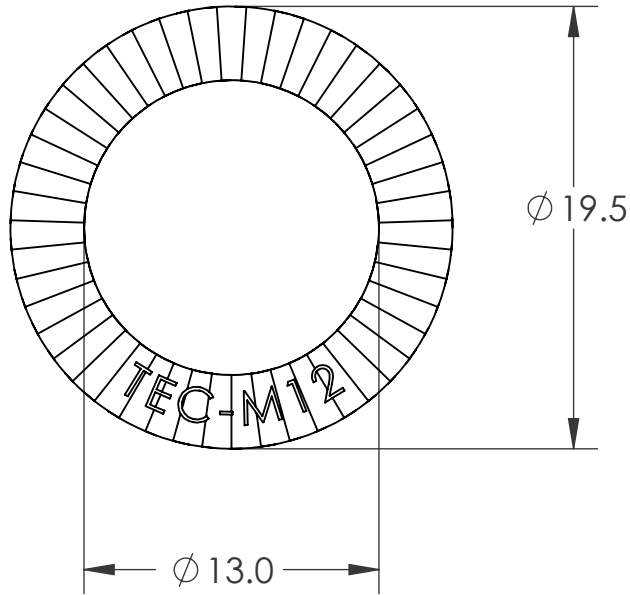

**PROPRIETARY AND CONFIDENTIAL**  
 THIS DRAWING, AND THE INFORMATION CONTAINED HEREIN, ARE THE PROPERTY OF SHEREX AND ARE NOT TO BE USED IN ANY MANNER DETRIMENT TO THE INTEREST OF THE COMPANY.  
 SHEREX FASTENING SOLUTIONS RESERVES THE RIGHT TO REVISE PART/DRAWING WITHOUT NOTICE.

DRAWING NO.:  
**TEC-M12**

UNLESS OTHERWISE SPECIFIED: DIMENSIONS ARE IN MILLIMETERS TOLERANCES: ANGULAR: MACH ±1 BEND ±1 I.D. TOLERANCE: ±0.2 O.D. TOLERANCE: ±0.2 THICKNESS TOLERANCE: ±0.25 INTERPRET GEOMETRIC TOLERANCING PER: ASME Y14.5M-1994 MATERIAL SCM435 OR 4130 STEEL, HT: THROUGH HARDEN 465 HV MIN FINISH DELTA PROTEKT BASE COAT (KL100) & TOP COAT (VH302GZ) DO NOT SCALE DRAWING	NAME	DATE	 <b>TECSERIES</b> <small>A SHEREX FASTENING SOLUTIONS® MARKET</small>						
	DRAWN	MTB		2/27/17					
	CHECKED								
	ENG APPR.	JVK		2/27/17					
	MFG APPR.		DESCRIPTION: <b>TEC WASHER GLUED PAIR 12MM</b>						
	Q.A.		<table border="1"> <tr> <td>SIZE</td> <td>PART NO.:</td> <td>REV</td> </tr> <tr> <td><b>A</b></td> <td><b>TEC-M12</b></td> <td><b>C</b></td> </tr> </table>	SIZE	PART NO.:	REV	<b>A</b>	<b>TEC-M12</b>	<b>C</b>
SIZE	PART NO.:	REV							
<b>A</b>	<b>TEC-M12</b>	<b>C</b>							
	COMMENTS: E-mail: <a href="mailto:info@disc-lock.com">info@disc-lock.com</a> <a href="http://www.disc-lock.com">www.disc-lock.com</a> Phone: 866-474-3739 Fax: 716-875-0358		<table border="1"> <tr> <td>SCALE: 2:1</td> <td>WEIGHT:</td> <td>SHEET 1 OF 1</td> </tr> </table>	SCALE: 2:1	WEIGHT:	SHEET 1 OF 1			
SCALE: 2:1	WEIGHT:	SHEET 1 OF 1							